



Ultrasonic Staking

In manufacturing products with thermoplastic components, it is often necessary to join a thermoplastic to a part of dissimilar material, whether it be metal, a dissimilar plastic, or other material. This technical information sheet provides design guidelines, configurations, and techniques for successful ultrasonic staking.

General Description

Ultrasonic staking is an assembly method that uses the controlled melting and reforming of a plastic stud or boss to capture or lock another component of an assembly in place. The plastic stud protrudes through a hole in the component to be locked in place. High frequency ultrasonic activity from the horn is imparted to the top of the stud, which melts and fills the volume of the horn cavity to produce a head, locking the component in place. The progressive melting of plastic under continuous but generally light pressure forms the head.

The advantages of ultrasonic staking include:

- Short cycle time (generally less than one second)
- Tight assemblies with virtually no tendency for recovery (memory)
- Minimal stress in the formed plastic
- The elimination of consumables such as screws and rivets.
- The ability to perform multiple stakes with one horn
- Repeatability and control over the process (consistent results)
- Design simplicity

Staking Considerations

In order to design the part correctly, a number of questions must first be answered:

1. What material is being used?
2. What strength will be required?
3. What loading must the stake resist in normal use (e.g., tensile, shear)?
4. Is appearance important?
5. Will multiple staking be necessary? If so, what is the distance between the studs?

6. Are the stakes recessed in the part and, if so, is there clearance for the horn?

These questions must be answered to determine the requirements of the application, for it is these requirements and the physical size of the stud(s) being staked that determine the type of design to be utilized.

Staking Configurations

The integrity of an ultrasonically staked assembly depends upon the volumetric relationship between the stud and horn cavity and the ultrasonic parameters used when forming the stud (e.g., amplitude of the horn, weld time, pressure). (See Figure 1.)

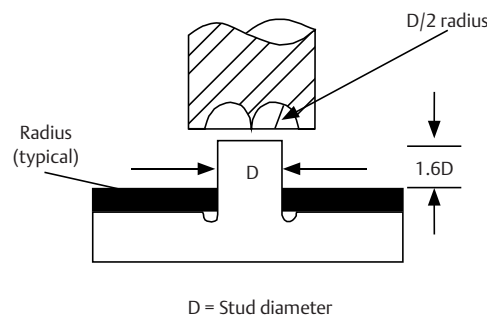

Figure 1. Relationship between stud and horn cavity

Proper stake design produces optimum strength and appearance with minimal or no flash.

Several configurations for stud/cavity design are available. The principle of staking is the same for each: The area of initial contact between the horn and stud should be kept to a minimum. This allows a concentration of the mechanical vibrations in a localized area to create a rapid melt, which speeds up the cycle on the part. This is true with each of the following designs, as well as customized designs to meet a specific part requirement.

Standard Profile Stake — The standard profile stake (Figure 2) is most commonly used for studs having a diameter between 1/8 and 5/32 inch (3.2 to 4 mm). The top of the molded stud is flat, and melt is initiated by the small, extended point in the

Applied Technologies Group

41 Eagle Road
Danbury, CT
06813-1961
(203) 796-0349
fax (203) 796-9838
email: info@bransonultrasonics.com

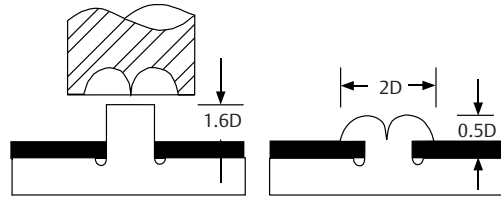

Figure 2. Standard profile stake

horn cavity. The head produced is twice the diameter of the stud and satisfies the requirements of the majority of staking applications. It is ideal for staking non-abrasive (unfilled) thermoplastics, both rigid and non-rigid. Standardized threaded horn tips for tapped horns are available for studs with diameters of 1/32 to 3/16 inch (0.8 to 4.8 mm). The standard profile should not be used for studs more than 5/32 inch (4 mm) in diameter. Low profile or hollow staking should be used. For studs less than 1/8 inch, the dome stake (described below) should be used.

Low Profile Stake — Low profile staking (Figure 3) is very similar to standard profile staking. It differs in the height of the finished staked head. This reduction of head height (low profile) is advantageous in applications where space is limited, and it improves cycle times; however, it produces a lower strength stake.

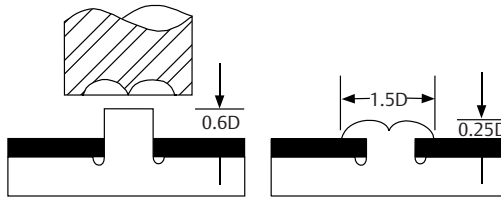

Figure 3. Low profile stake

Dome Stake — The dome stake (Figure 4) is recommended for studs with a diameter of 1/8 inch (3.2 mm) or less, or where multiple studs are being staked. It is especially useful for very small diameters, or when the material is glass- or mineral-filled.

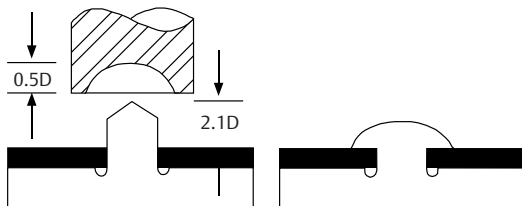

Figure 4. Dome stake

The top of the stud should be tapered (cone-shaped), the point of which initiates material melt, reducing energy being transmitted through the stud. Alignment between the horn and the stud is not as critical as with the standard profile, because the tip and part will self-align. The dome staking

tip is less susceptible to wear than the standard profile tip when glass-filled materials are being staked.

Knurled Stake — The knurled stake (Figure 5), available in both male and female patterns, is designed for simplicity and rapid rate of assembly, and is used when appearance and strength are not critical. There is no dimensioned horn cavity, and multiple stakes may be made without concern for precise alignment or stud diameter. A hand-held welding tool may be utilized.

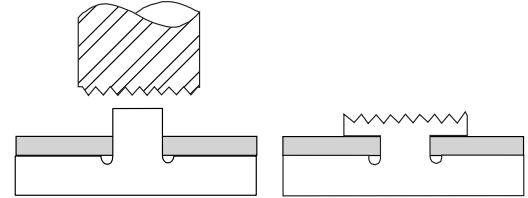

Figure 5. Knurled stake

Flush Stake — For applications requiring a flush surface and having sufficient thickness in the contained piece to allow for a recess, the flush stake (Figure 6) is ideal. The tapered stud design used for dome staking is recommended, and a flat-faced horn or tip is utilized. Flush staking may be used for all thermoplastics.

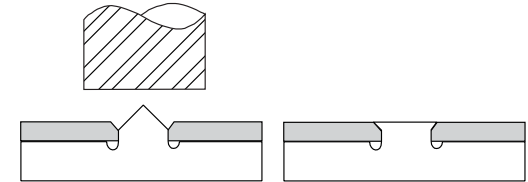

Figure 6. Flush stake

Hollow Stake — The hollow stake (Figure 7) is generally used when studs are equal to or greater than 3/16 inch (4.8 mm) in diameter. Hollow studs offer advantages in molding, because they prevent surface sinks and internal voids. Staking a hollow stud produces a large, strong head without having to melt and displace a large volume of material.

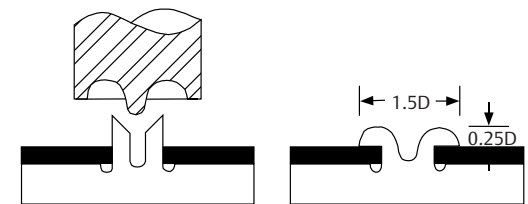

Figure 7. Hollow stake

Also, where disassembly for repair is a primary requirement of the application, repairs can be made by removing the formed stud head for access to internal components and driving a self-tapping screw into the inside diameter of the stud for reassembly.

Process Parameter Guidelines

When setting up a staking application, use the following standard process parameters as a guideline:

- Slow downspeed
- Pretrigger of low Dynamic Trigger setting
- Low pressure
- Medium to high amplitude (refer to Branson Amplitude Reference Guide, TL-2)
- Rigid support under studs

Multiple Staking

In many cases, more than one stud may be staked in a single operation. The feasibility of multiple staking is determined by the ability to design a horn that will function properly. The horn used for multiple staking can be half-wavelength or composite in design. If the studs are on the same plane and within 1/2 inch (12.7 mm) of each other, a half-wave horn is recommended. Large parts having studs widely spaced on the same plane would require a full-wave composite horn to provide the necessary amplitude for staking.

Staking Techniques

Two methods are recommended for staking, depending upon the material and staking requirements: the conventional method, which is most frequently used, and the high-pressure method. Both methods of staking require the stud to be properly located and rigidly supported directly below to ensure correct alignment with the horn cavity, and that energy will be expended at the horn/stud interface rather than exciting the entire plastic assembly and fixture.

Conventional Method

In this instance, the intent is to localize the ultrasonic energy at the top of the plastic stud, so only this area of the stud begins to melt. The mechanics used to generate this method of melt staking often require pretriggering (energizing the ultrasonic horn) prior to contacting the top of the stud.

The horn descends onto the stud at a preset speed and pressure (bearing force) to allow surface melting of the stud to occur. It is important that the downspeed of the horn is not faster than the melting rate of the plastic stud; this prevents the stud from being deformed or buckling.

The plastic stud melts into the cavity of the horn. A hold (dwell) time is then required to allow solidification of the reformed stud head. Sufficient clamp force between the formed head and the horn during solidification will keep the parts tightly locked together.

High-Pressure Method

This method involves reforming the plastic stud without reaching its melting temperature on the surface, creating a condition that softens and forms the stud into a mushroom shape when using a flat-faced horn. (Cavities may also be used.) The high-pressure method works best with resilient materials such as ABS and high-impact styrene or polyethylene and polypropylene. However, it has also been found to work well with more rigid materials such as polycarbonate and acetal.

The mechanics used to accomplish high-pressure staking require high force between the working face of the horn and the top of the plastic stud before energizing the ultrasonic horn, and using a low-amplitude horn.

The horn reforms the stud to generate a mushroom head on the top of the stud. The travel distance selected can permit the parts joined to move freely or be tightly locked together. It is recommended that only low profile plastic studs be used to help prevent stud bending (deflection) when high pressure is applied between the top of the stud and horn. Figure 8 shows a cross section of a mushroom-formed stud.

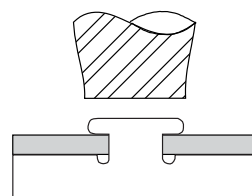

Figure 8. High-pressure stake

Process parameters for the high-pressure method are as follows:

- Medium downspeed
- Medium to high Dynamic Trigger setting
- Medium to high pressure
- Low amplitude
- Rigid support under the studs.

Other Design Guidelines

No matter which particular staking configuration is chosen, there are certain design features or characteristics that are generic. Designing with these in mind can maximize the effectiveness and consistency of the process.

1. **A radius** at the base of the stud helps to eliminate areas of high stress concentration, such as is found in sharp corners. Two ways to incorporate this radius are illustrated in Figure 9. Failure to add this detail could result in burning or fracturing of the stud at the base instead of dissipating the energy at the horn/stud interface.

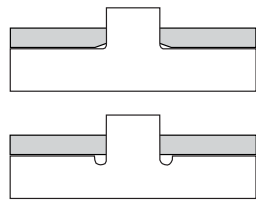

Figure 9. Incorporating a radius in stud/part design

2. **Part-to-part fit** regarding the diameter of the stud and the through-hole is critical. As was stated earlier, the integrity of the formed head is a volumetric relationship between the cavity and displaced material. Variations in part-to-part fit could change this relationship resulting in inconsistency. For example, a gap along the walls between the stud diameter and hole diameter (see Figure 10) could allow some of the displaced material to flow into the gap, making less material available to form the head. It is, therefore, recommended that the fit be as close as possible.

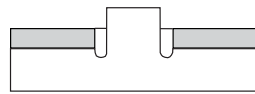

Figure 10. Part-to-part fit

Characteristics of Thermoplastic Polymers for Staking

The codes in the following table indicate relative ease of staking for the more common thermoplastic polymers. Use the table as a guide only, since variations in resins may produce slightly different results.

Note: The ratings below do not relate to the strength of the weld obtainable. Refer to Technical Information Sheet PW-1 for detailed polymer information.

Material Ease of Staking

Amorphous Polymers

ABS	1
ABS/polycarbonate alloy	2
Acrylic	4
Acrylic multipolymer	2
Butadiene-styrene	2
Phenylene-oxide based resins	2
Polycarbonate	3
Polystyrene (general purpose)	4
Polystyrene (rubber modified)	1
Polysulfone	3
PVC (rigid)	2
SAN-NAS-ASA	4
Xenoy (PBT/polycarbonate alloy).	4

Semi-Crystalline Polymers

Acetal	3
Cellulosics.	2
Liquid crystal polymers	3
Nylon	3
Polyethylene	3
Polymethylpentene	3
Polyphenylene sulfide	5
Polypropylene	1

Code: 1 = easiest, 5 = most difficult

Ordering Information

Standard and low profile staking tips are listed below; other profiles such as dome or hollow staking tips can be made to special order.

Tip Dia.	Identification Letter and Description	Stud Dia.	Stud Length*	EDP No.
1/2"	A std. prof.	1/32" x 0.050"	101-148-034	
1/2"	B std. prof.	1/16" x 0.100"	101-148-035	
1/2"	C std. prof.	3/32" x 0.150"	101-148-036	
1/2"	D std. prof.	1/8" x 0.200"	101-148-037	
1/2"	E std. prof.	5/32" x 0.250"	101-148-038	
1/2"	F std. prof.	3/16" x 0.300"	101-148-039	
1/2"	G low prof.	1/32" x 0.019"	101-148-040	
1/2"	H low prof.	1/16" x 0.038"	101-148-041	
1/2"	I low prof.	3/32" x 0.056"	101-148-042	
1/2"	J low prof.	1/8" x 0.075"	101-148-043	
1/2"	K low prof.	5/32" x 0.094"	101-148-044	
1/2"	L low prof.	3/16" x 0.112"	101-148-045	
5/8"	M std. prof.	7/32" x 0.350"	101-148-046	
5/8"	N std. prof.	1/4" x 0.400"	101-148-047	
5/8"	O low prof.	27/64" x 0.253"	101-148-048	
5/8"	P low prof.	15/32" x 0.281"	101-148-049	

*Stud length is defined as the length of the stud that protrudes above the material to be staked.

Staking tip kit containing all the above tips and a storage case: 101-063-027

**Branson
Worldwide
Headquarters**

41 Eagle Road
Danbury, CT
06813-1961
info@BransonUltrasonics.com

© Branson Ultrasonics Corporation, 1980
Revised and Printed in U.S.A. 1/06