



Part Design for Ultrasonic Welding

Ultrasonic energy has been used to join thermoplastics for over 35 years. Ultrasonic welding of thermoplastic materials is by far the most common form of ultrasonic assembly, and is used extensively in all major industries including automotive, appliance, electronic, toy, packaging, textile, and medical. It offers advantages in speed, economy, and efficiency, and is frequently chosen when parts are too complex or expensive to be molded in one piece.

This bulletin provides guidelines to aid the designer during the initial concept stage of a new product design, ensuring optimum production results. The dimensions given in the designs should be used as *guidelines only*, since the specifics of your application may require variations. If you have questions or need assistance in designing your parts, contact your local Branson representative, regional technical center, or Branson headquarters in Danbury, Connecticut.

Primary Factors Influencing Joint Design

All of the following basic questions must be answered prior to the design stage to gain a total understanding of what the weld joint must do:

- What type of material(s) is to be used?
- What is the overall part size and configuration?
- What are the final requirements of the part?
 - Is a structural bond desired and, if so, what load forces does it need to resist?
 - Is a hermetic seal required? If so, to what pressure?
 - Does the assembly require a visually attractive appearance?
 - Is flash or particulate objectionable inside and/or outside?
 - Any other requirements?

Three Major Joint Design Characteristics

In order to obtain acceptable, repeatable welded joints, three general design guidelines must be followed:

1. **The initial contact area between the mating surfaces should be small** to concentrate and decrease the total energy (and thus the time) needed to start and complete melting. Minimizing the time the vibrating horn remains in contact with the part also reduces the potential for scuffing, and since less material is moved, there is less flash.
2. **A means for aligning** the mating parts should be provided. Features such as pins and sockets, steps, or tongues and grooves, should be used for alignment rather than the vibrating horn and/or fixture, to ensure proper, repeatable alignment and to avoid marking.
3. **Horn contact and placement** must be considered to provide proper bearing over the joint area, to direct the mechanical energy and force to prevent marking of the contact surface.

Two Major Types of Joint Design

There are two major types of joint design: the **energy director** and the **shear joint**. All other joint variations can be classified under these general categories or as hybrids combining aspects of both.

Energy Director

The **energy director** is typically a raised triangular bead of material molded on one of the joint surfaces. The primary function of the energy director is to concentrate the energy to rapidly initiate the softening and melting of the joining surface.

The diagrams in Figure 1 (next page) show time-temperature curves for a common butt joint and the more ideal joint incorporating an energy director. The energy director permits

Branson

41 Eagle Road
Danbury, CT
06813-1961
(203) 796-0400
fax (203) 796-9838
email: info@bransonultrasonics.com

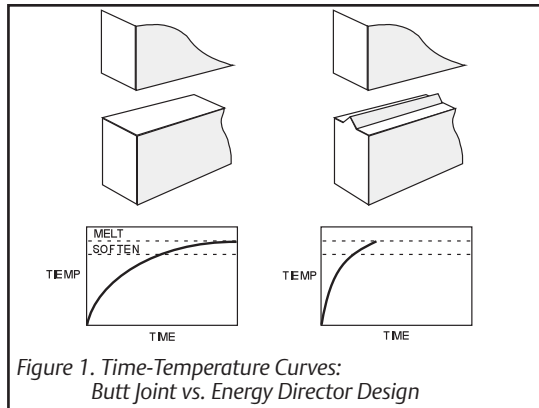

Figure 1. Time-Temperature Curves:
Butt Joint vs. Energy Director Design

rapid welding while achieving maximum strength; material within the director generally flows throughout the joint area. The energy director is the most commonly-used design for amorphous materials, although it is also used for semi-crystalline materials.

Butt Joint with Energy Director

The basic design formula for the energy director design is illustrated in Figure 2. It is very important to remember that the size and location of the energy director on the joint interface are dependent upon:

- Material(s)
- Requirements of the application
- Part size.

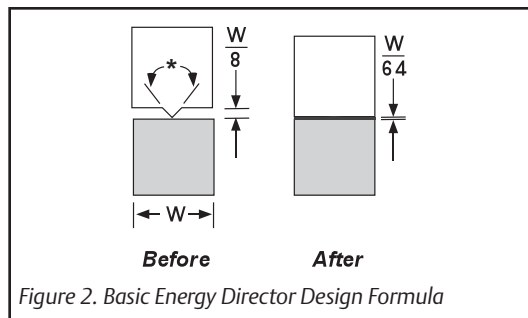

Figure 2. Basic Energy Director Design Formula

The peak of the energy director should be as sharp as possible; energy directors that are round or flat at their peak will not flow as efficiently.

When using a relatively easy-to-weld resin (e.g., polystyrene which has high modulus [stiffness] and low melt temperature), a minimum height of 0.010 inch (0.25 mm) is suggested, whereas a semi-crystalline or high-temperature amorphous resin (e.g., polycarbonate)

*NOTE: Typically a 90° included angle is used for amorphous resins, while a 60° included angle is used for semi-crystalline resins. The included angle may vary depending on materials, fillers, part geometry, or requirements. For your specific application, please contact your local sales engineer or regional office for recommendations.

would require a minimum height of 0.015 inch (0.4 mm).

In the case of semi-crystalline resins (e.g., acetal, nylon) with an energy director, the maximum joint strength is generally obtained only from the width of the base of the energy director.

As a rule, it doesn't make any difference which half of the part contains the energy director. In special situations (as in combinations of different materials), the general practice is to place the energy director on the part with the material that has the highest melt temperature and stiffness.

The energy director design requires a means of alignment such as pins and sockets, aligning ribs, tongue and groove designs, or fixturing. Knockout pins should not be placed in the weld area.

Variations of the Energy Director Joint

The basic energy director design can be incorporated into joint configurations other than the butt joint to gain additional benefits. Examples of joint design variations utilizing an energy director include the following alternatives:

Step Joint — The step joint is used for alignment and for applications where excess melt or flash on one exposed surface is objectionable. (Figure 3.) Note that 0.010 to 0.025 inch (0.25 to 0.64 mm) has been added to the gap surrounding the perimeter of the part. This adds a feature called a "shadow line" to the design.

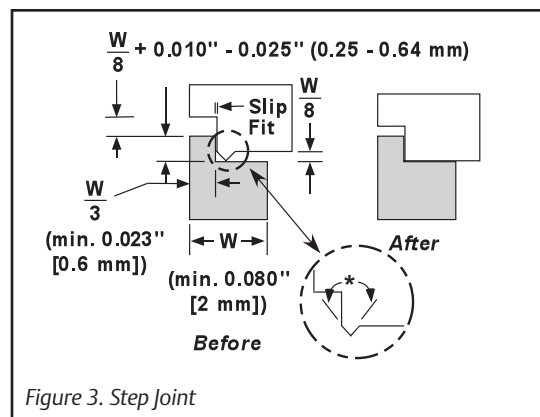

Figure 3. Step Joint

When welding is completed, a 0.010 to 0.025 inch (0.25 to 0.64 mm) gap will be formed around the periphery of the part, creating a more appealing appearance, since part-to-part variations will be less noticeable. If the gap were completely closed, it is likely that flash would be formed in some outside areas, with slight gaps in others; whereas with the shadow

line, minor variations in the parts are less likely to be noticed.

The design of the energy director uses the same basic design thought process used in the butt joint energy director (i.e., material, requirements, part size). Note that a minimum wall thickness of 0.080 inch (2 mm) is recommended for this design.

Tongue and Groove — The major benefits of using this joint design are that it prevents flash, both internally and externally, and provides alignment. Containment of the material enhances the attainment of hermetic seals. The need to maintain clearance on both sides of the tongue, however, makes this more difficult to mold. Also, because of the reduced weld area, it is generally not as strong as a step joint. (Figure 4.)

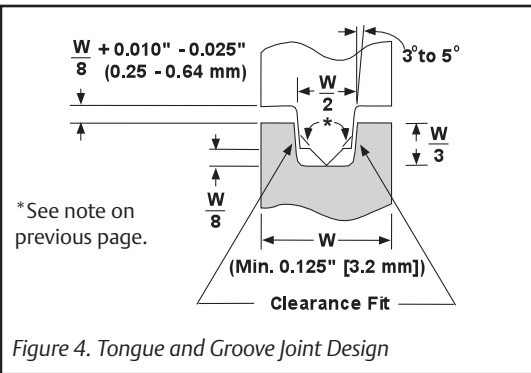

The design of the energy director uses the same basic design thought process used in the butt joint energy director (i.e., material, requirements, part size).

Textured Surface** — This feature is exclusively used in conjunction with an energy director. Molding a textured surface on the

Branson/MoldTech Texture Designation	Pattern Depth	
Branson 300/11040	0.003"	
Branson 450/11050	0.0045"	
Branson 600/11050-0.006	0.006"	

Figure 5. Textured Surface

mating part tends to improve the overall weld quality and strength by enhancing frictional characteristics and melt control. (Figure 5.)

Usually the texture is 0.003 to 0.006 inch deep (0.076 to 0.152 mm), and is varied based on the height of the energy director. In most cases,

**This design is covered by Branson Patent No. 4,618,516. License to utilize this design is granted via the purchase of Branson equipment.

the advantages include increased weld strength, reduced flash or particulate, reduced weld times, or lower amplitude requirements. (Branson TechnoLog TL-4 provides details on this concept.)

Criss-Cross — This design incorporates energy directors on both mating sections that are perpendicular to each other, and provides minimum initial contact at the interface while allowing a potentially larger volume of material involvement. This can result in increased strength in the weld. (Figure 6.) Each energy director should be dimensioned at approximately 60% of the size that would be used in a standard single energy director design, with an included angle of 60° versus the standard 90°.

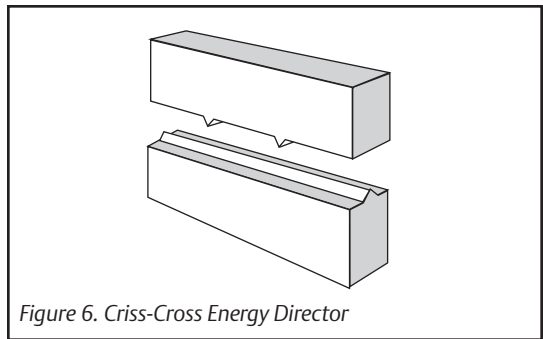

If an air- or liquid-tight seal is required, it is recommended that the corresponding energy directors be continuous, like a saw tooth. (Figure 7.) The corresponding saw-tooth energy directors must be located on the part that will be contacted by the horn. Note that this design generates a very high material flow; therefore, containing flash should be addressed in part design (e.g., use a tongue and groove or step design).

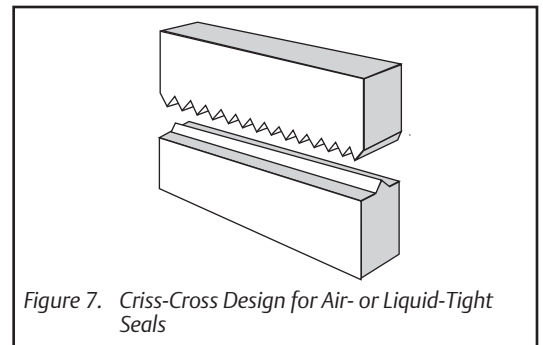

Energy Director Perpendicular to the Wall — Used to gain resistance to peeling forces and to reduce flash. (Figure 8.) This design should be used when only a structural seal is required.

Interrupted — Used to reduce the overall area and subsequent energy or power level required, or to minimize part marking. Use only where

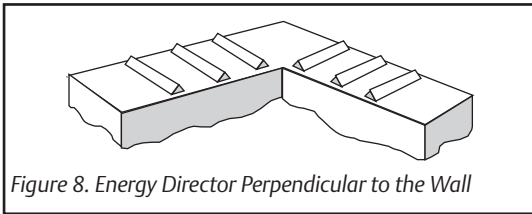

Figure 8. Energy Director Perpendicular to the Wall

structural (non-hermetic) seals are needed. (Figure 9.)

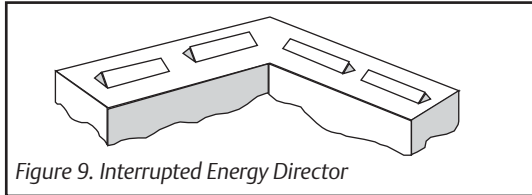

Figure 9. Interrupted Energy Director

Chisel Energy Director — Typically used when nominal wall thickness is 0.060 inch (1.524 mm) or less. (Figure 10.) If a standard energy director is used, it will be too small (less than 0.010 inch/0.254 mm tall), thus resulting in lower weld strengths. The knife edge can be 0.015 inch to 0.020 inch (0.381 to 0.508 mm) tall and should utilize a 45° angle. As weld strength will be limited to weld width, a textured surface should always be added when using this design.

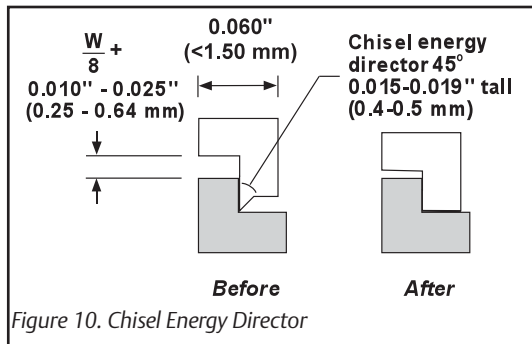

Figure 10. Chisel Energy Director

Specialized Joints — In order to achieve a hermetic seal in less easily welded resins or irregular shapes, it may be necessary to use a compressible seal or a convoluted path for melt flow. Figure 11 shows a joint design incorporating an O-ring. It is important to note that the O-ring should be compressed a maximum of 10 to 15%, only at the end of the weld. Pins and sockets (stud welding) can also be used successfully with an O-ring design. (See data sheet PW-5.)

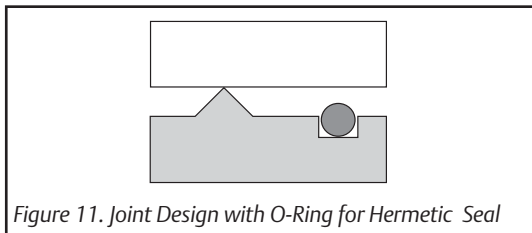

Figure 11. Joint Design with O-Ring for Hermetic Seal

Shear Joint

An energy director type of joint design in some cases may not produce the desired results with semi-crystalline resins such as nylon, acetal, polypropylene, polyethylene, and thermoplastic polyester. This is due to the fact that semi-crystalline resins change rapidly from a solid to a molten state, and back again, over a relatively narrow temperature range. The molten material flowing from an energy director, therefore, could re-solidify before fusing with the adjoining interface. The weld strength in a semi-crystalline resin could be limited to the base width of the energy director. A **shear joint** configuration is recommended for these resins where geometry permits.

With a shear joint design, welding is accomplished by first melting the small, initial contact area and then continuing to melt with a controlled interference along the vertical walls as the parts telescope together. (Refer to Figure 12.) This allows a strong structural or hermetic seal to be obtained as the molten area of the interface is never allowed to come in contact with the surrounding air. For this reason, the shear joint is especially useful for semi-crystalline resins.

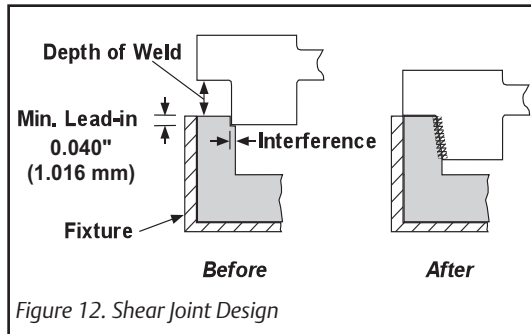

Figure 12. Shear Joint Design

The strength of the welded joint is a function of the vertical dimension of meltdown of the joint (depth of weld), which can be adjusted to meet the requirements of the application.

Note: For joint strength meeting or exceeding that of the wall, a depth of 1.25X the wall thickness is recommended.

IMPORTANT: The shear joint requires rigid side wall support to prevent deflection during welding. The walls of the bottom section must be supported at the joint by the holding fixture, which conforms closely to the outside configuration of the part. The top part should be of sufficient structural integrity to withstand internal deflection.

For a midwall joint, the tongue and groove variation shown in Figure 13 is preferred. It is also useful for large parts. Interference on one side only is recommended.

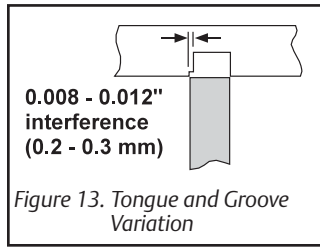

Figure 13. Tongue and Groove Variation

Figure 14 shows variations of the basic shear joint design.

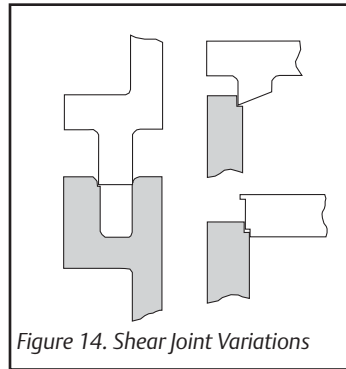

Figure 14. Shear Joint Variations

It should be noted that a shear joint is not recommended for parts with a maximum dimension of 3.5 inch or greater, sharp corners, or irregular shapes. This is due to difficulty in holding the molding tolerances necessary to obtain consistent results. An energy director type joint would be suggested for parts falling outside of these parameters (i.e., 3.5 inch, sharp corners, irregular shapes).

When welding parts that need a structural weld only (strength or air-tight seals are not required), use the shear joint design with interrupted vertical energy directors shown in Figure 15. This design reduces the overall area and subsequent energy or power required to weld the parts. The potential for part marking is also minimized.

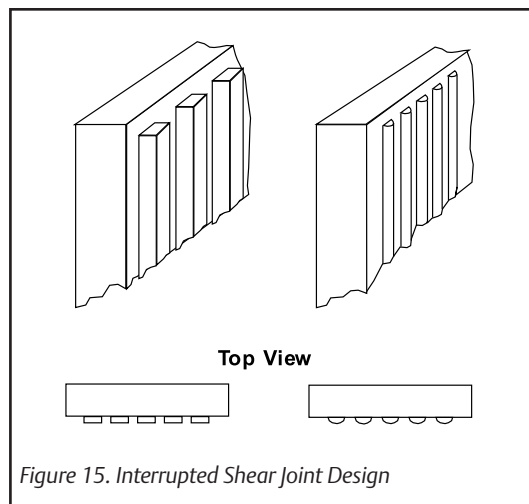

Figure 15. Interrupted Shear Joint Design

Shear Joint Interference Guidelines

The following table gives general guidelines for interference and part tolerance in relation to maximum part dimension.

Maximum Part Dimension	Interference per Side (Range)	Part Dimension Tolerance
Less than 0.75" (18 mm)	0.008" to 0.012" (0.2 to 0.3 mm)	±0.001" (±0.025 mm)
0.75" to 1.50" (18 to 35 mm)	0.012" to 0.016" (0.3 to 0.4 mm)	±0.002" (±0.050 mm)
1.50" to 3.50" (38 to 90 mm)	0.016" to 0.020" (0.4 to 0.5 mm)	±0.003" (±0.075 mm)

Other Design Considerations for Any Joint Design

Sharp corners localize stress. When a molded part with stress concentration is subjected to ultrasonic mechanical vibrations, damage (fracturing, melting) may occur in the high stress areas. This can be remedied by having a generous radius (0.020 inch/0.508 mm) on corners, edges, and junctions. At a minimum, all corners or edges should be broken. (Refer to Figure 16.)

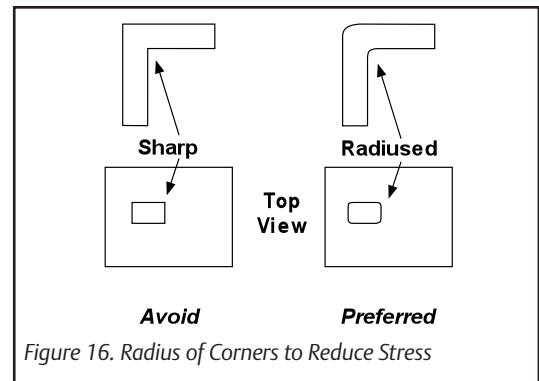

Figure 16. Radius of Corners to Reduce Stress

Holes or voids like ports or other openings in the part being contacted by the horn can create an interruption in the transmission of the ultrasonic energy (Figure 17). Depending on the type of material (especially semi-crystalline resins) and the size of the hole, little or no welding will occur directly beneath the opening. When a hole or bend exists in the part, the resin dampens the transmission of energy, making it difficult to pass vibrations from the

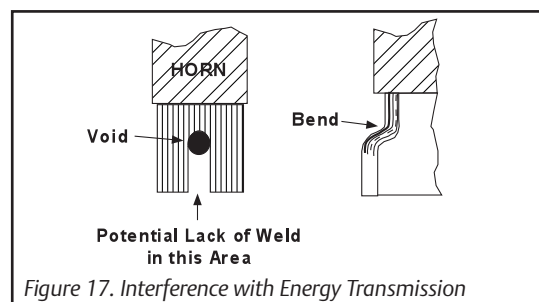

Figure 17. Interference with Energy Transmission

horn contact point to the interface of the parts to be welded, especially in shear.

Careful attention must be given to the design of parts to avoid such problem areas. Air bubbles within the plastic, due to improper venting in the mold tool, will also dampen the transmission of vibrations or cause the material to blow out in these areas.

Near-field vs. far-field welding—Near-field welding refers to a joint 0.250 inch (6.35 mm) or less from the horn contact surface; far-field welding to a joint more than 0.250 inch from the horn contact area. (Figure 18.)

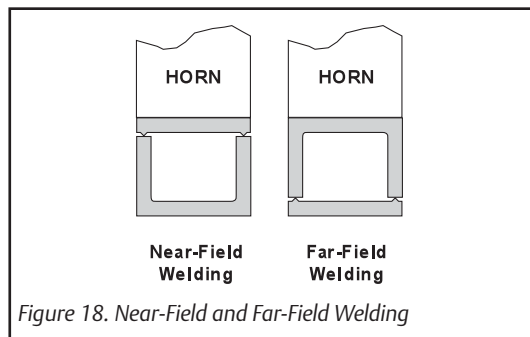

Figure 18. Near-Field and Far-Field Welding

As mentioned above, because of their structure semi-crystalline resins dampen the transmission of energy, making them more difficult to weld far-field. In amorphous plastics, the random arrangement of molecules allows the vibrations to pass through easily with little attenuation. Dampening also takes place in low-stiffness resins (low modulus). Care must be taken when designing parts to allow adequate transmission of energy to the joint area.

Appendages, tabs, or other details molded on to the interior or exterior surfaces of the molding can be affected by the mechanical vibrations, resulting in fracturing. (See Figure 19.) The following are recommended to minimize or eliminate this:

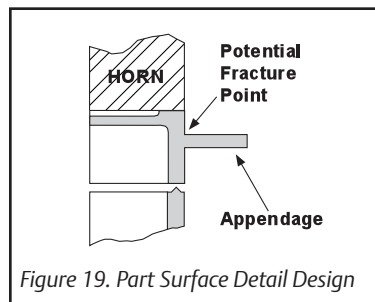

Figure 19. Part Surface Detail Design

- The addition of a generous radius to the area where the appendages intersect the main part.
- Dampening of flexure through external means.

- Increasing the material thickness.
- Evaluation of other frequencies.

Diaphragm—an “oil-canning” effect with related burn-through—typically occurs in flat, circular parts in thin-walled sections of the part (e.g., a living hinge) contacted by the horn. (See Figure 20.) This can be corrected by one or a combination of the following:

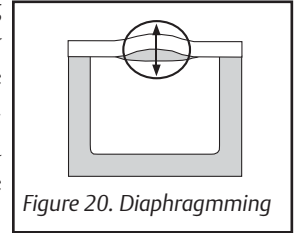

Figure 20. Diaphragm

- Shorter weld time
- Higher or lower amplitude
- Amplitude Profiling™
- Nodal plunger on horn
- Thicker wall section
- Internal support ribs
- Evaluation of other frequencies.

Horn contact and placement can play a major role in the successful welding of molded parts. In general, the horn should be large enough to overhang the perimeter of the parts, so it is bearing directly over the joint area. (Refer to Figure 21.) Doing this helps direct the mechanical energy and prevent marking of the contact surface. The surface of the horn or part can also be raised over the weld area to provide better contact; this will improve the consistency of energy transmission. *Note:* The area of horn-to-part contact must be larger than the total weld area. Failure to do this could lead to surface marking.

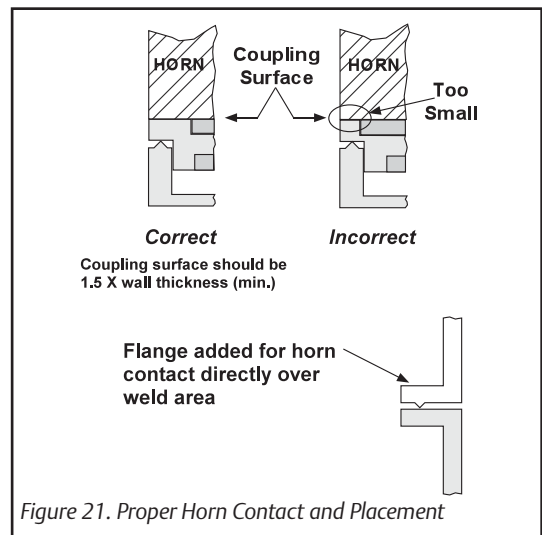

Figure 21. Proper Horn Contact and Placement

**Branson
Worldwide
Headquarters**

41 Eagle Road
Danbury, CT
06813-1961
info@BransonUltrasonics.com

PW-3
© Branson Ultrasonics
Corporation, 1975
Printed in U.S.A. 2/09